

Leakage Sealant (Xypex) Sealant Effectiveness Test

Result Report (Vol. 1)

June 22, 1993

Summary

June 1st, 1993

Test of Effectiveness in Sealing Concrete Crack and Repairing Leakage by Brush Method

1.0 Purpose

The purpose of this test is to confirm the effectiveness of Xypex Concentrate (Concrete Waterproofing by Crystallization, abbreviation: XC) in sealing leaks in tunnel lining concrete. The test was performed at Kajima Building Research, Department #1, Laboratory #1, with the attendance of The Department of Construction, Tokyo City Hall.

2.0 Test Procedure

1. Test Pieces: Size: ϕ 300 X 200 l
Compressive Strength:
401 kgf / cm² (1-Week)
428 kgf / cm² (2-Week)
Cracks: On the 7th day after concrete casting, the sample pieces were cracked by compression.
Cracks Width = 0.1 - 0.2 mm
Cracks on the side of samples were coated with resin.
2. Water Pressure: Sample #1: 2 kgf / cm²
Sample #2: 2 kgf / cm² at the beginning
After leakage stopped, the surface layer of Xypex was removed and the pressure was increased to 4 kgf / cm².
(Xypex was applied again when minor leakage started.)
3. XC Application: XC and water were mixed for 3 minutes with the ratio of W/XC = 35%. The sample was placed with the crack in a horizontal position. After pressurized water was pumped from behind, leakage was observed. XC was applied (3 cm in width) with the crack in the center.

(Note) Considering the amount of leakage, the injection method would have been more practical on site. However, the brushing method was used in this test. Therefore, the layer of XC below the crack was washed away soon after the application.
4. Measurement: The sample pieces were set up as shown in the attached figure and placed in a pan. The leaked water was collected from a hole in the pan and measured in a graduated cylinder.

3.0 Sample Pieces and Their Setup

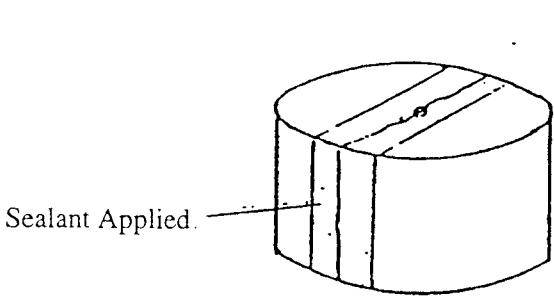

Sample (Side and Back View)
(Water penetration was limited in order to maintain the water pressure.)

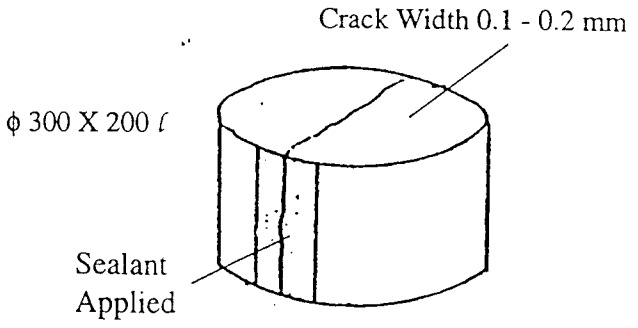

Sample (Front View)

2 kgf/cm², 4kgf/cm²

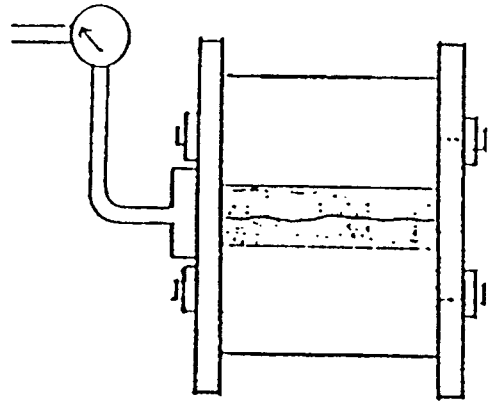

Sample Setup (Side View)

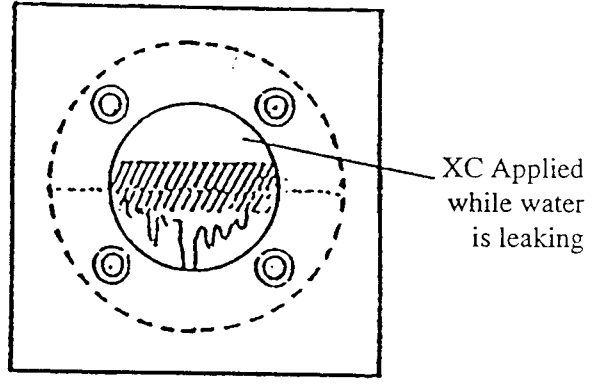

Sample Setup (Front View)
(XC below the crack was washed away)

4.0 Test Results

The attached figures show the test results.

With both samples, the leakage stopped in the end. Thus the effectiveness of Xypex in sealing leakage was confirmed. Especially, with Sample #2, Xypex was proven to be durable enough for actual field use, since the leakage was stopped at 4.0 kgf/cm² (3.9 X 10⁵ Pa) of pressure.

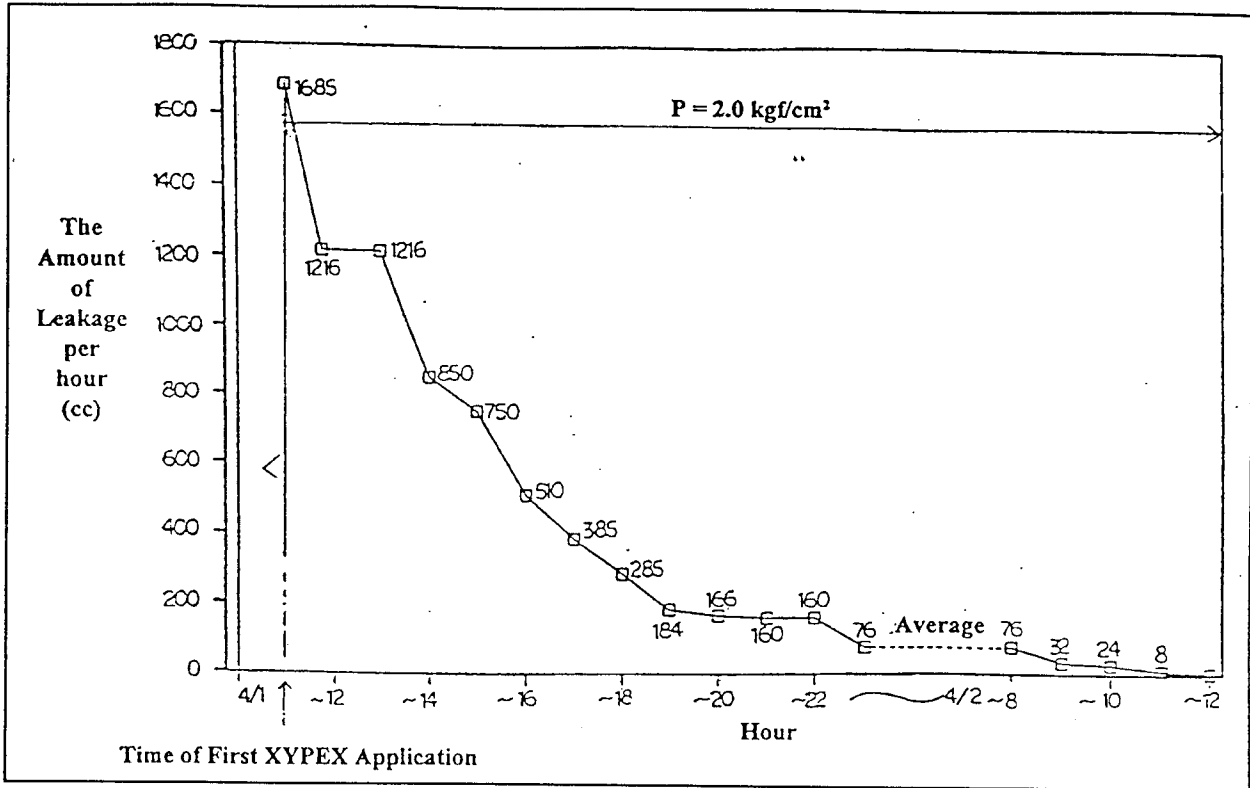

Figure 1 Test Results (Sample #1)

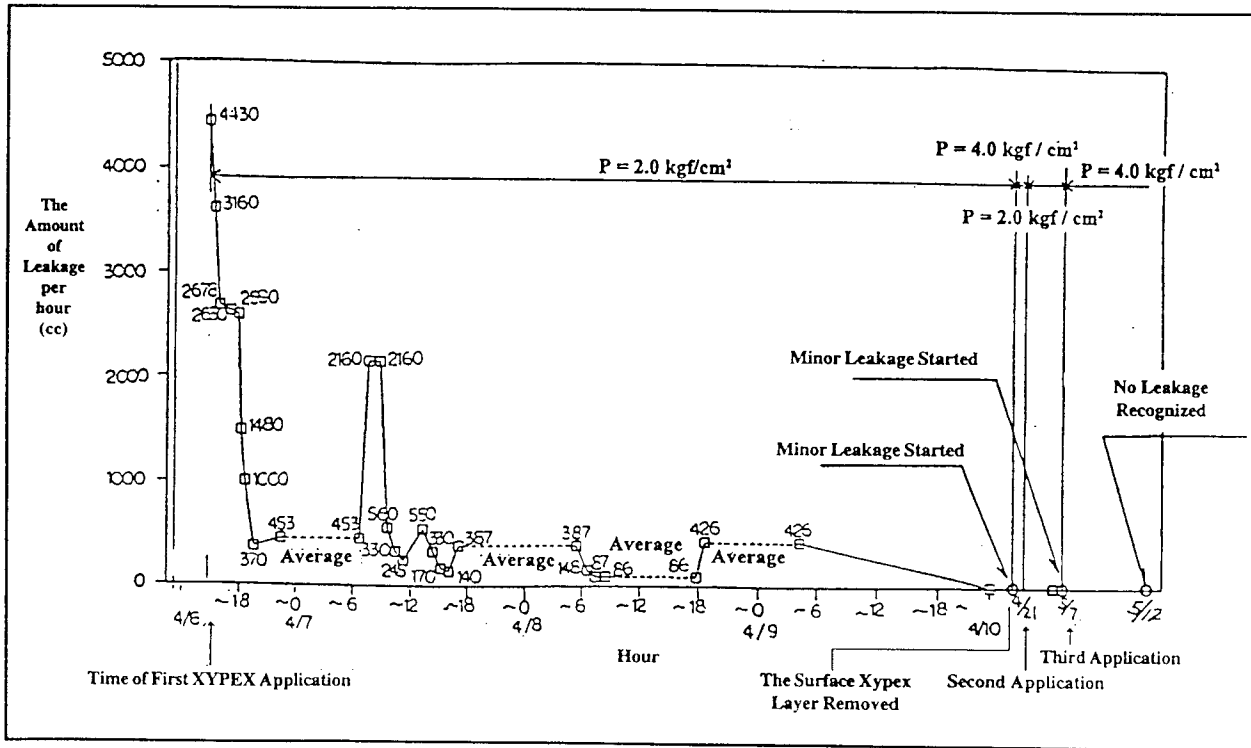

Figure 2 Test Results (Sample #2)

Table of Contents

1.0	Purpose.....	6
2.0	Sample Pieces and Their Preparation.....	6
2.1	Sample Pieces.....	6
2.2	Materials.....	7
2.2.1	Sample Pieces.....	7
2.2.2	Repairing Agent.....	7
2.3	Sample Piece Casting.....	7
2.4	Sample Piece Property Tests.....	7
3.0	Tests.....	8
3.1	Test Procedure.....	8
3.2	Test Equipment.....	11
3.3	Test Conditions.....	11
3.4	Cracking the Sample Pieces by Compression.....	12
4.0	Measurement.....	13
5.0	Test Results.....	13
6.0	Test Schedule.....	16
	Appendix.....	17

1.0 Purpose

The purpose of this test is to evaluate the effectiveness of Xypex in repairing cracks in tunnel lining concrete.

2.0 Sample Pieces and Their Preparation

2.1 Sample Pieces

The sample pieces were cylindrical concrete blocks as shown in Figure 2.1. It was assumed that the top and bottom surface cracks (caused by compression) represented the actual crack throughout the sample piece. Other cracks and the side surface of the samples were sealed with resin in order to allow leakage only from the monitored part.

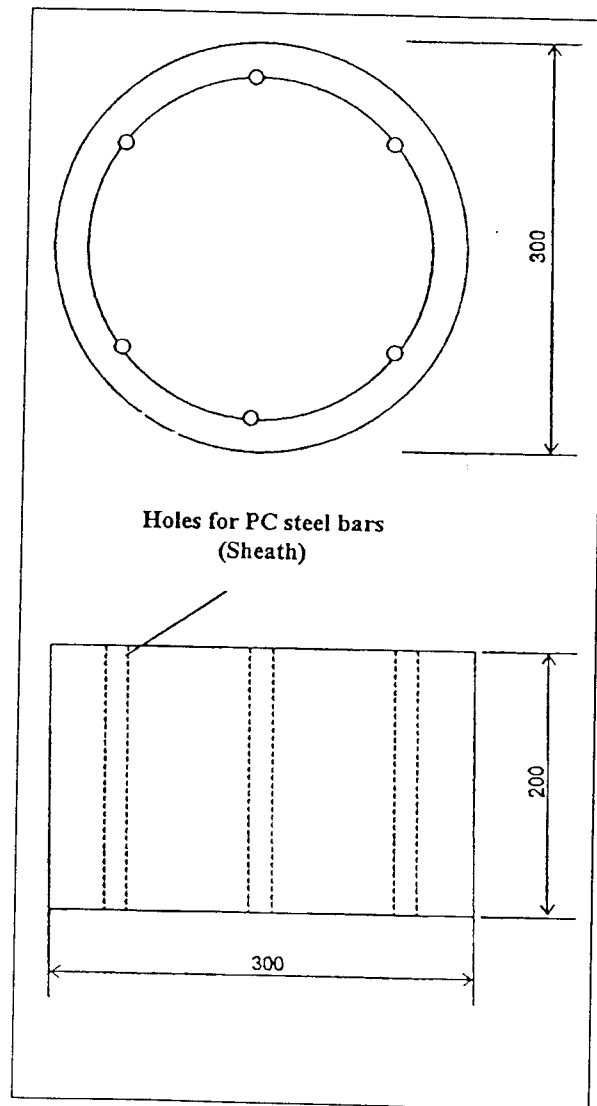

Figure 2.1 Sample Piece Concrete Block

2.2 Materials

2.2.1 Sample Pieces

20-12-400 ready mixed concrete was used to cast the sample concrete blocks. High-early-strength cement was used because of the test schedule.

D10, SD295 was used for reinforcement. Figure 1 shows the reinforcement.

2.2.2 Repairing Agent

Xypex (by Japan Xypex Inc.) was used as a repairing agent.

2.3 Sample Piece Casting

Sample pieces were made in Building #5 Laboratory, Kajima Building Research. Five concrete blocks were cast including extra sample pieces.

For the mold, FujiVoid (inside diameter 300 x thickness 5.5, by Fujimori Industries) was used.

2.4 Sample Piece Property Tests

The following tests were performed when the concrete was fresh:

Slump Test (JIS A 1101-1975)

Air Content Test (JIS A 1128-1975)

The following test was performed when the concrete had hardened:

Compressive Strength Test (JIS A 1108-1976)

The table below shows the test results.

	Slump	Air Content	Compressive Strength	
			1-Week	At the time of the test (2-Weeks)
Test Results	13.5 cm	6.4 %	401	428 kgf/cm ²

Table 2.1 Sample Property Test Results

3.0 Tests

3.1 Test Procedure

The test of repairing effectiveness was performed in Building #5 Laboratory, Kajima Building Research. The site plan of the building was shown in Figure 3.1.

A concrete permeability testing machine (owned by Kajima Building Research) was used in this test. The machine converted the air pressure from an air compressor to water pressure, which was applied to the sample pieces. Figure 3.2 shows the compression system, and Figure 3.3 shows the test procedure.

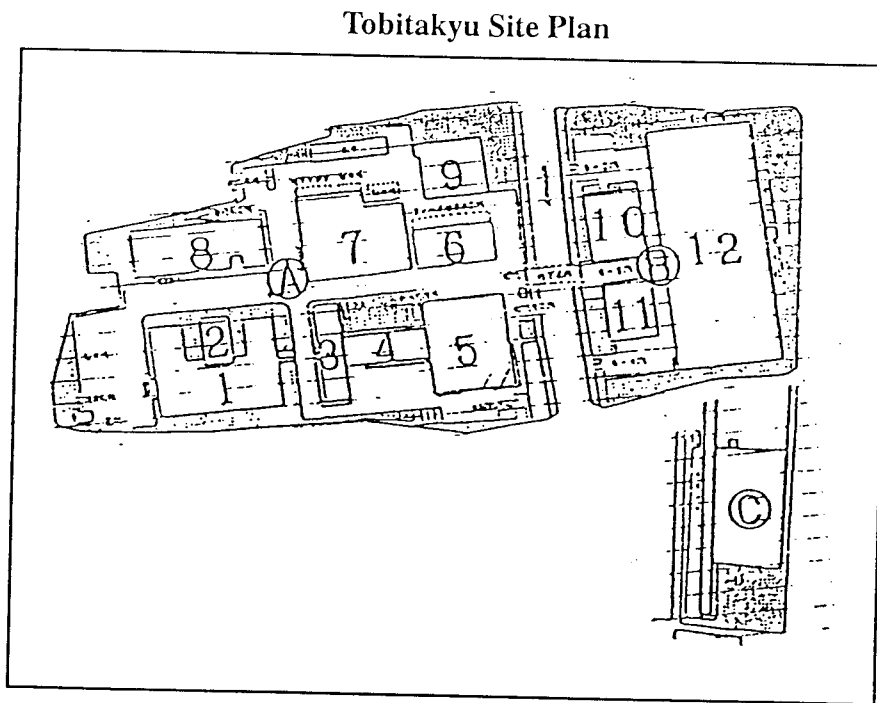

Figure 3.1 Laboratory Location

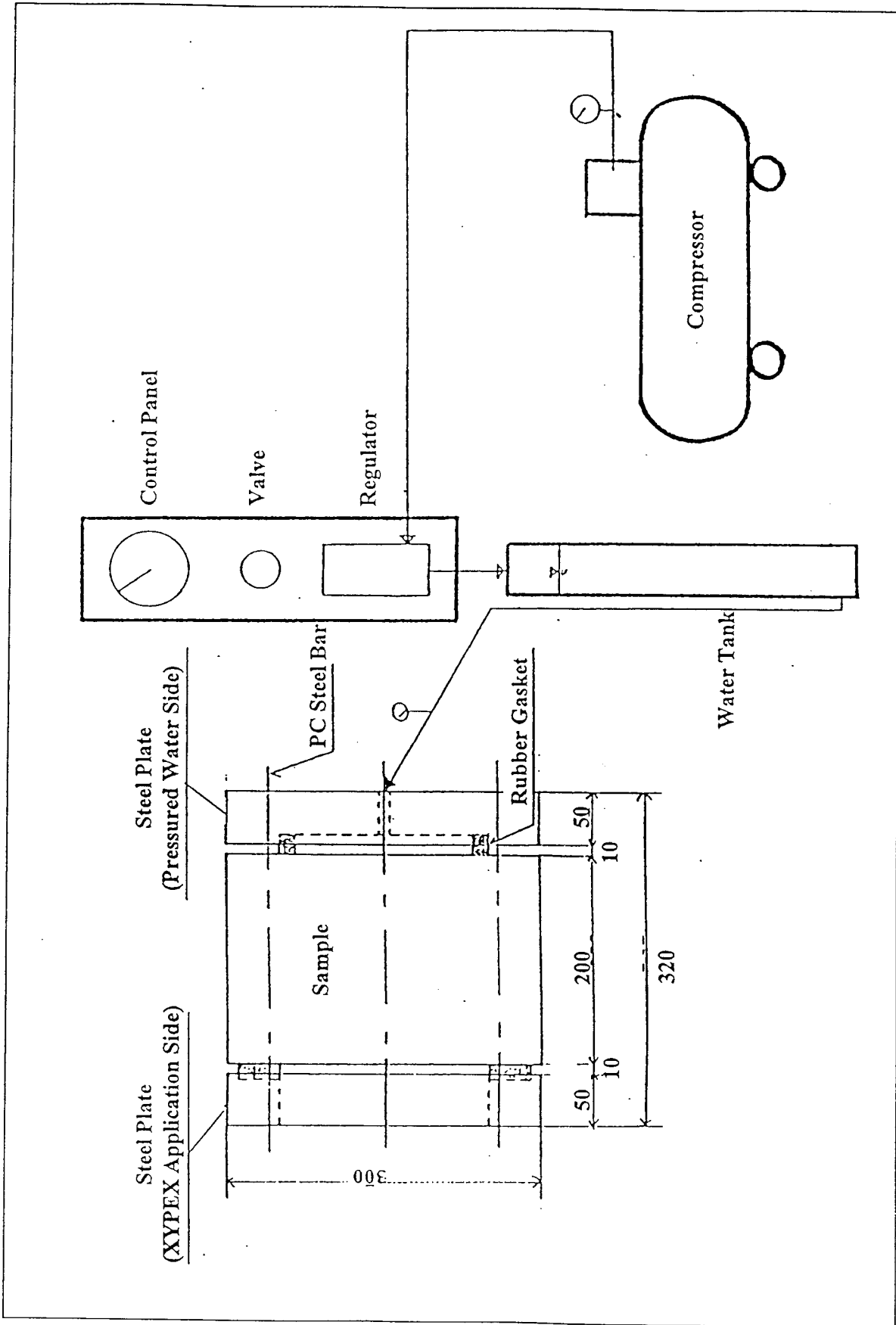

Figure 3.2 Compression System

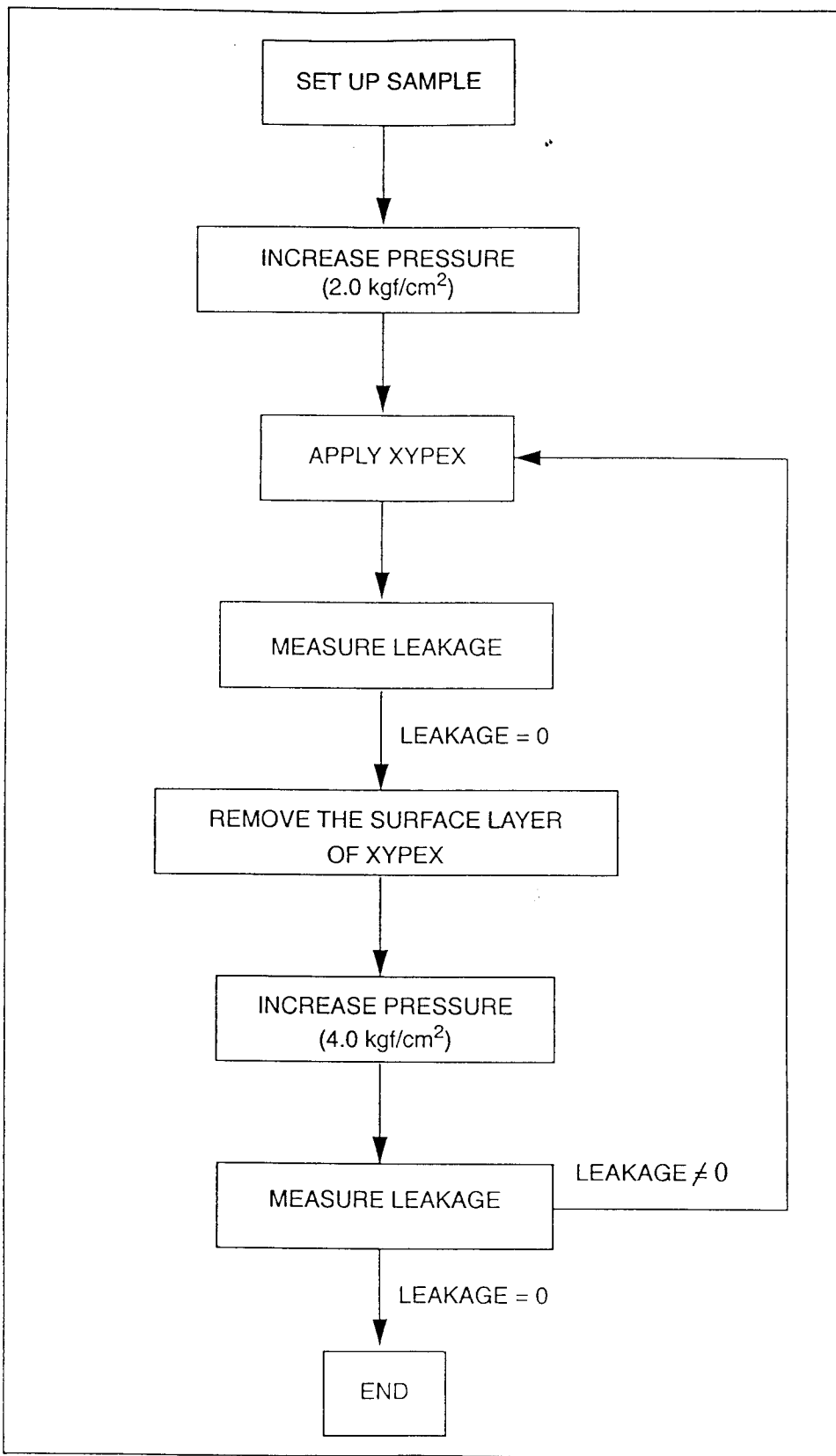

Figure 3.3 Test Procedure

3.2 Test Equipment

On both sides of the concrete block samples, square steel plates with rubber gaskets were attached and tightened with PC steel bars.

On the pressurized water side, there was a clearance between the concrete block and the steel plate in order to assure even pressure on the concrete surface. On the Xypex application side, a window was cut away in the center of the steel plate for Xypex application and observation.

The plates were made of a steel sheet 50 mm thick. The PC steel bar to tighten the steel plates and the concrete block was type A #1, SBPR 785/930 ϕ 9.2. The steel plates are shown in Figure 2.

The rubber gaskets were the same size as the outer diameter (200 mm), the inside diameter (170 mm). The gasket cross section is 20 mm X 15 mm, and is made of Neo Plain rubber.

3.3 Test Conditions

Test conditions were determined as follows, depending on the intended field use.

- When the leakage stopped, the surface Xypex layer was removed, and the water pressure was increased to 4.0 kgf/cm² (3.9 X 10⁵ Pa).
- The water used in testing was sampled from a site, considering the fact that Xypex penetrates into concrete as the chemical reaction proceeds.

Table 3.1 shows the test conditions.

	Sample #1	Sample #2	On-Site Test
Sample Size	ϕ 300 x 200 (mm)		Thickness 600 mm
Crack Width	0.1 - 0.2 mm		
Sample Age	10 days	15 days	---
Pressure Incline	Max 2 kgf/cm ² /20 cm	Max 4 kgf/cm ² /20 cm	4 kgf/cm ² /20 cm
Water	Tap Water	Sampled on Site	Sampled on Site
Repairing Agent	XYPEX		
XYPEX Application	1 time	3 times	---

Table 3.1 Test Conditions

3.4 Cracking the Sample Pieces by Compression

The sample pieces were cracked by compression using a 100t Amsler type testing machine. In order to make the remaining crack width the same as field cracks (0.1-0.2 mm), after the cracking has started, the load was increased and then removed each time, and the crack width was measured.

Figure 3.4 shows the cracks on the two samples which were used for the test.

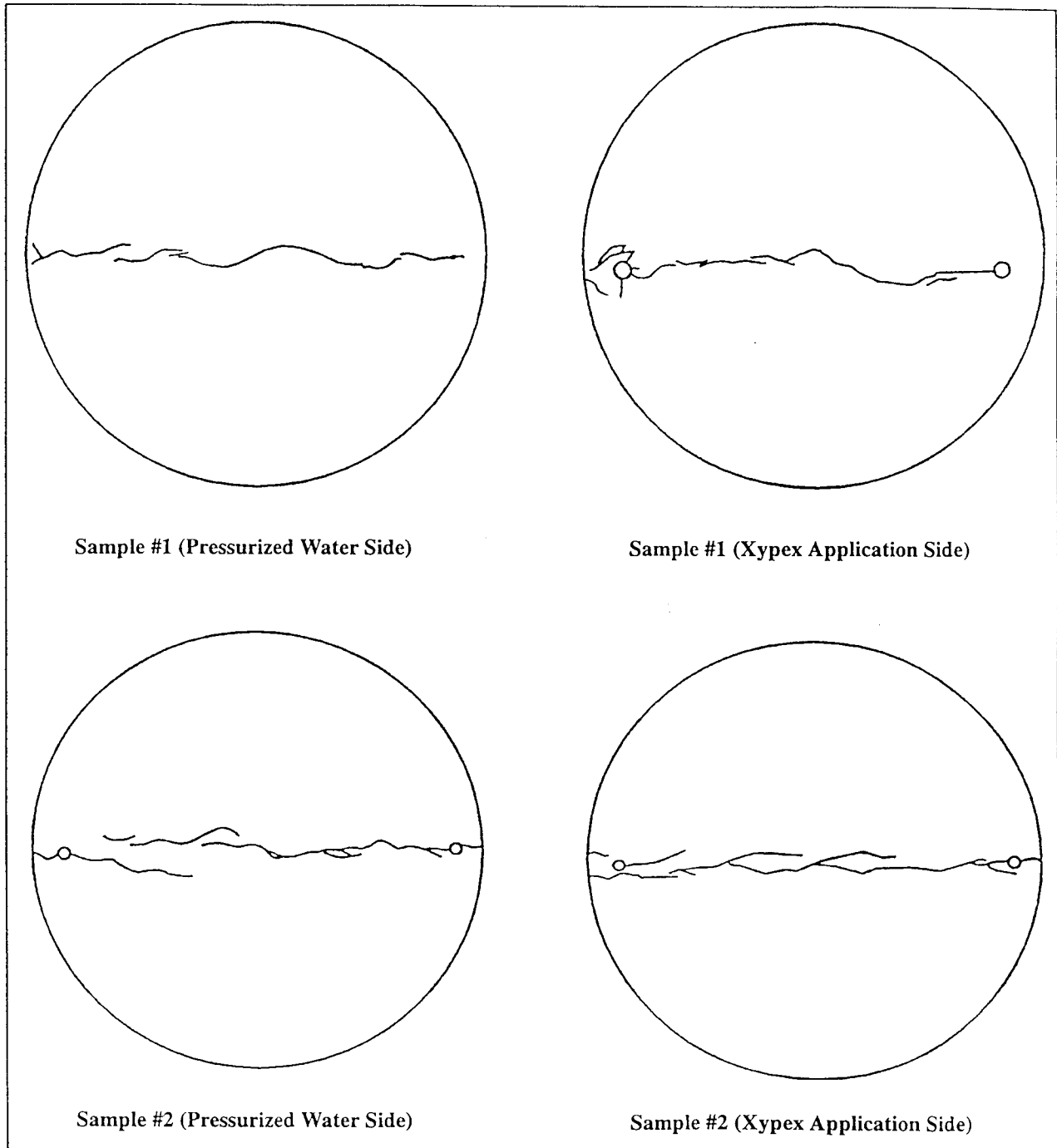

Figure 3.4 Sample Piece Cracks

4.0 Measurement

During the test, the water pressure was monitored by the pressure gauge attached on the steel plate on the pressurized water side.

To evaluate the effectiveness of Xypex, the amount of leakage was measured.

5.0 Test Results

Figure 5.1 and 5.2 show the test results.

With both samples, the leakage stopped in the end. Thus the effectiveness of Xypex in sealing leakage was confirmed. Especially, with Sample #2, Xypex was proven to be durable enough for actual field use, since the leakage was stopped at 4.0 kgf/cm² (3.9×10^5 Pa) of pressure.

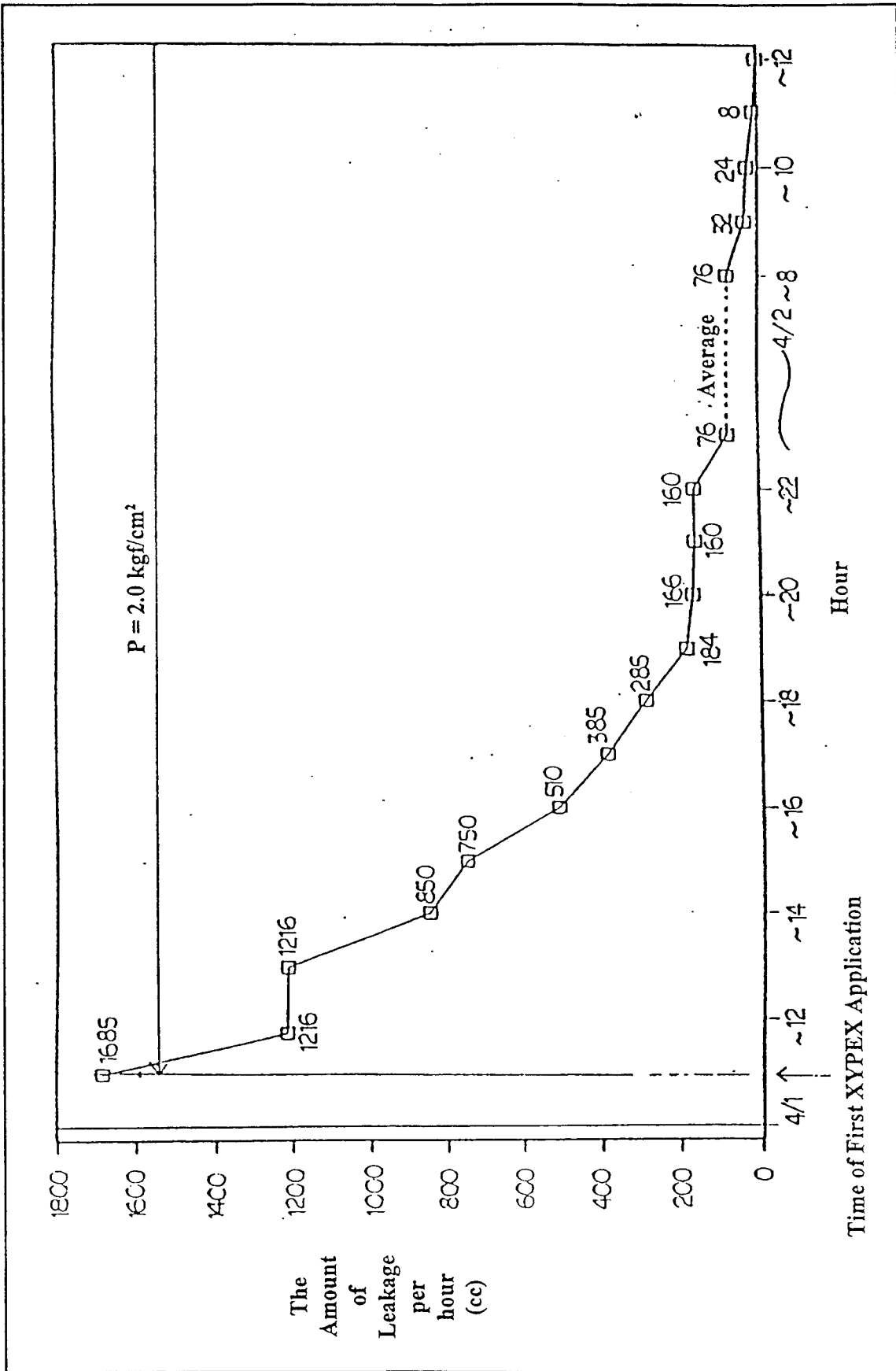

Figure 5.1 Test Results (Sample #1)

